CITY OF BUCYRUS

DRIVEWAY INSTALLATION / CURB INSTALLATION AND CUTTING PERMIT

(BUCYRUS CODIFIED ORDINANCE CHAPTER 907)

DRIVEWAY _____ CURB INSTALLATION _____ CURB CUT _____

PROPERTY OWNERS NAME: _____

ADDRESS: _____

_____ (TELEPHONE)

CONTRACTOR: _____

ADDRESS: _____

_____ (TELEPHONE)

EXPLANATION OF PROJECT: _____

LENGTH ALONG STREET TO BE CUT OR INSTALLED: _____

DRIVEWAY APRON MATERIAL AND THICKNESS TO CONFORM TO BCO 1131.08

FEE= _____ RECEIPT # _____

OWNER'S SIGNATURE: _____ DATE _____

APPROVED _____ DENIED _____

SERVICE-SAFETY DIRECTOR: _____ DATE _____

COMMENTS: _____

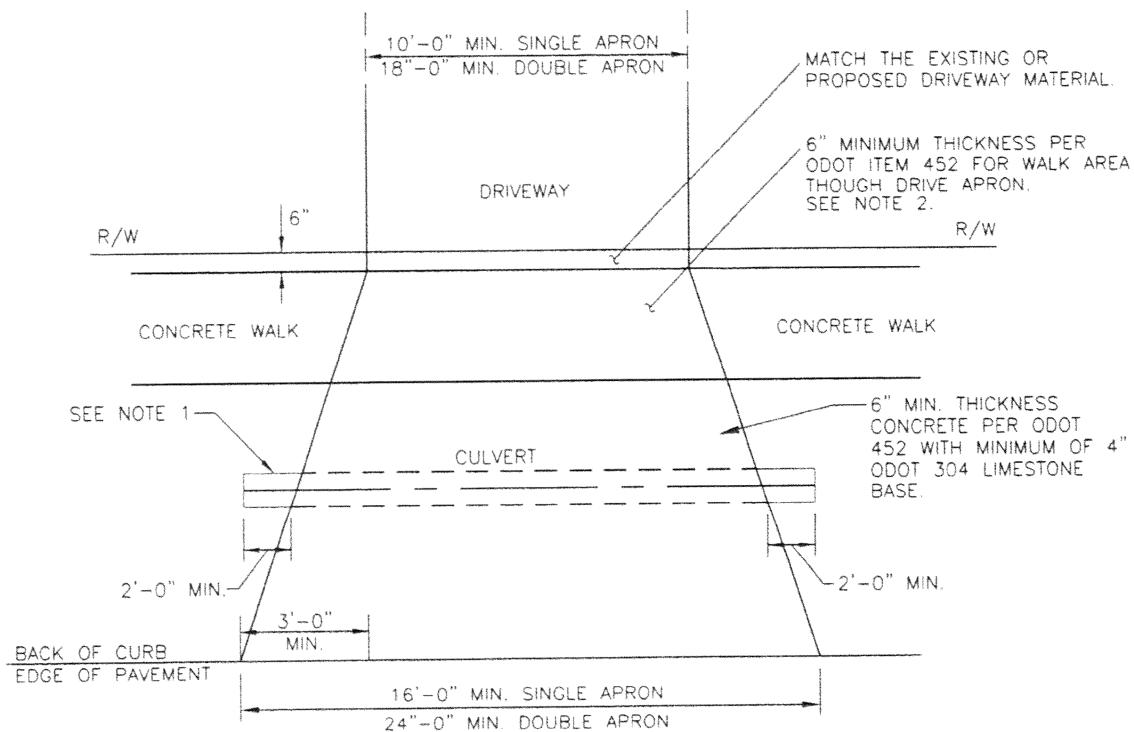

- NOTES:**
1. IF DITCH EXISTS, A DRIVE CULVERT MUST BE INSTALLED 8" DIAMETER MINIMUM. CULVERT SHALL BE SIZED FOR UPSTREAM DRAINAGE AREA TO PREVENT DRIVE OVER TOPPING.
 2. CONCRETE WALK WIDTH SHALL MATCH ADJOINING WALK, 4' MINIMUM WIDTH.

RESIDENTIAL DRIVE APRON DETAIL

NO SCALE

City Of Bucyrus
Standard Construction Details

SD-5-01

Copyright - Aug 21, 2010 - 4 58pm CT Consultants, Inc. Drawing name: H:\2008\080501\080501\Standard Details\SD-5-01.DWG. Layout: Layout by: etrans

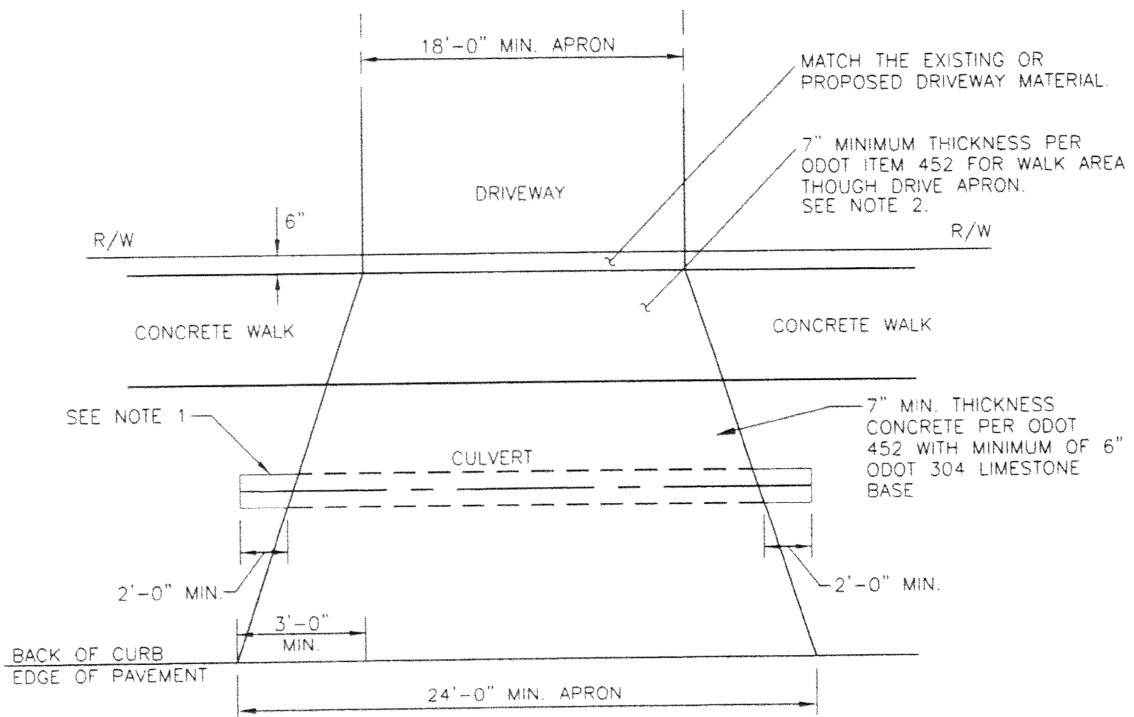

NOTES:

1. IF DITCH EXISTS, A DRIVE CULVERT MUST BE INSTALLED 8" DIAMETER MINIMUM. CULVERT SHALL BE SIZED FOR UPSTREAM DRAINAGE AREA TO PREVENT DRIVE OVER TOPPING.
2. CONCRETE WALK WIDTH SHALL MATCH ADJOINING WALK, 4' MINIMUM WIDTH.

COMMERCIAL DRIVE APRON DETAIL

NO SCALE

City Of Bucyrus
Standard Construction Details

SD-5-02

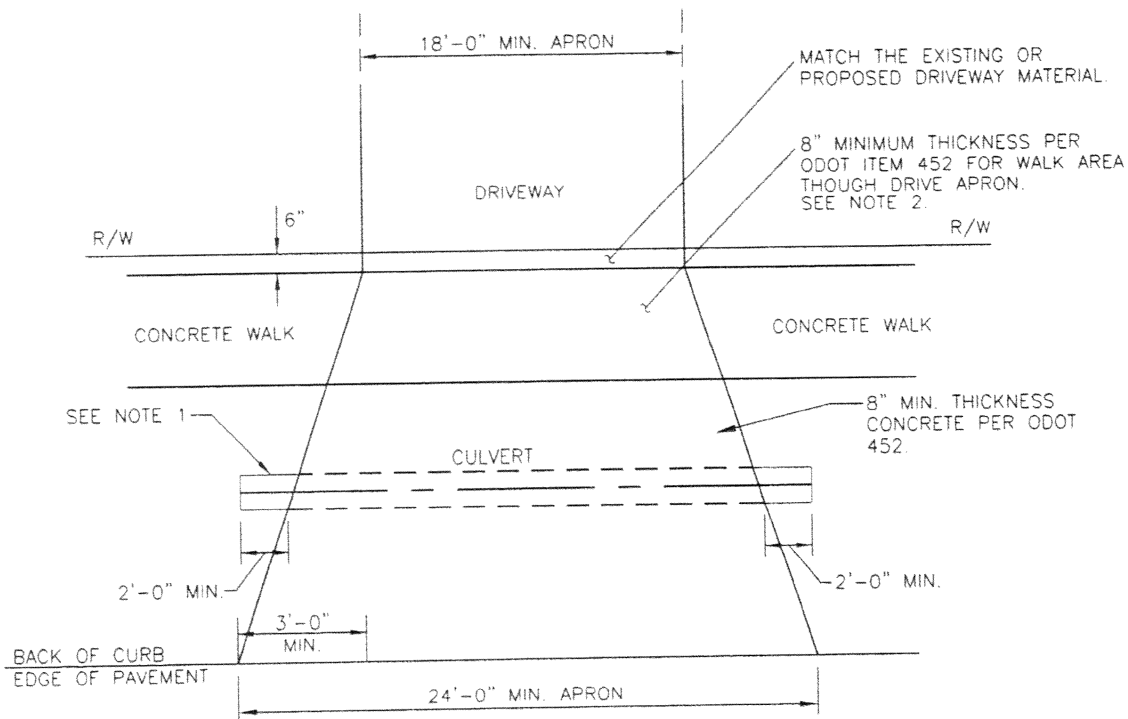

NOTES:

1. IF DITCH EXISTS, A DRIVE CULVERT MUST BE INSTALLED 8" DIAMETER MINIMUM. CULVERT SHALL BE SIZED FOR UPSTREAM DRAINAGE AREA TO PREVENT DRIVE OVER TOPPING.
2. CONCRETE WALK WIDTH SHALL MATCH ADJOINING WALK, 4' MINIMUM WIDTH.

INDUSTRIAL DRIVE APRON DETAIL

NO SCALE

City Of Bucyrus
Standard Construction Details

SD-5-03